

# BST12/12i

Lithium-Ion Stacker Truck

Lithium-Ion Stacker Truck with initial lift  
1200 kg



# DIMENSIONS

## BST12

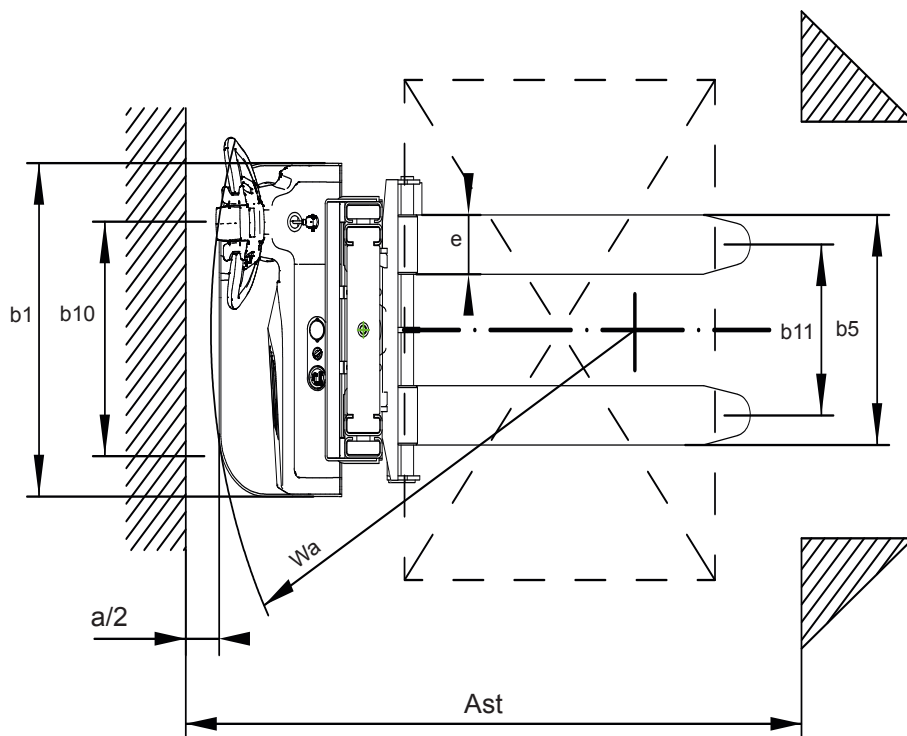
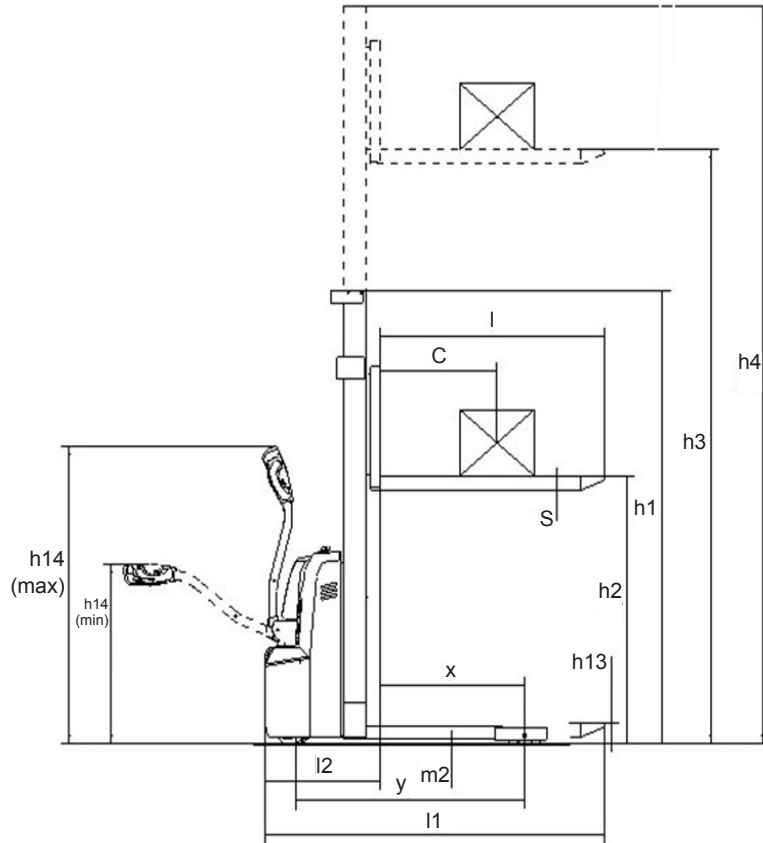

For corresponding data see specification chart.

# SPECIFICATIONS

## Product specification acc. to VDI 2198

	1.1	Manufacturer (Abbreviation)	CLARK	CLARK	
Specifications	1.2	Manufacturer's designation	BST12	BST12i	
	1.3	Drive unit	Electric-24V	Electric-24V	
	1.4	Operator type stand on/driver seated	Pedestrian	Pedestrian	
	1.5	Load capacity/rated load	Q (kg)	1200	1200
	1.6	Load centre distance	c (mm)	600	600
	1.8	Load distance, centre of drive axle to fork face	x (mm)	741	788
	1.9	Wheelbase	y (mm)	1180	1268
Weight	2.1	Service weight	kg	525	615
	2.2	Axle loading, laden front/rear	kg	474 / 1251	769 / 1046
	2.3	Axle loading, unladen front/rear	kg	386 / 139	190 / 425
Tyres, Chassis	3.1	Tyres	Polyurethane	Polyurethane	
	3.2	Tyre size, front	Ø 195 x 70	Ø 195 x 70	
	3.3	Tyre size, rear	Ø 80 x 70	Ø 80 x 70	
	3.4	Additional wheel (diemensions)	Ø 150 x 60	Ø 150 x 60	
	3.5	Wheels, number front/rear (x = drive wheels)	1x+1/4	1x+1/4	
	3.6	Tread, front	b <sub>10</sub> (mm)	523	523
	3.7	Tread, rear	b <sub>11</sub> (mm)	410	390
Dimensions	4.2	Height of mast, lowered	h <sub>1</sub> (mm)	2200	2272
	4.4	Lift height *1	h <sub>3</sub> (mm)	3300	3300
	4.5	max.height of mast, extended	h <sub>4</sub> (mm)	3860	3892
	4.6	Initial lift	h <sub>5</sub> (mm)	-	120
	4.9	Height drawbar in driving position min./max.	h <sub>14</sub> (mm)	670/1300	670/1300
	4.15	Lowered fork height	h <sub>13</sub> (mm)	90	90
	4.19	Overall length	l <sub>1</sub> (mm)	1748	1789
	4.20	Length to face of forks	l <sub>2</sub> (mm)	598	639
	4.21	Width	b <sub>1</sub> (mm)	800	800
	4.22	Fork dimensions	s*e*I (mm)	60*180*1150	70*180*1150
	4.25	Width across forks min/max	b <sub>5</sub> (mm)	570	570
	4.32	Ground clearance centre of wheelbase	m <sub>2</sub> (mm)	30	17~137
	4.34.1	Stacking aisle for pallets (l6 · b12) 1000 x 1200 across	Ast (mm)	2218	2286
	4.34.2	Stacking aisle for pallets (l6 · b12) 800 x 1200 along	Ast (mm)	2173	2224
4.35	Turning radius	Wa (mm)	1365	1450	
Performance	5.1	Travel speed laden/unladen	km/h	4.5 / 4.5	4.5 / 4.5
	5.2	Lift speed laden/unladen	m/s	0.12/0.18	0.16 / 0.24
	5.3	Lowering speed laden/unladen	m/s	0.22/0.21	0.22/0.21
	5.8	max. gradeability laden/unladen (S2 5 min.) *2	%	6/15	6/15
	5.10	Service brake		electro magnetic	electro magnetic
Drive line	6.1	Drive motor output (S2 60 Min.)	kW	0.65	0.65
	6.2	Lift motor output S3 15 %	kW	3.0	3.0
	6.4	Battery voltage, nominal capacity K5	V/Ah	24/60	24/60
Misc.	6.5	Battery weight	kg	20	20
	10.7	Sound level, driver's ear DIN/EN 12053	dB (A)	70	70

\*1) Further lifts heights to be found in mast overview \*2) At friction coefficient  $\mu=0.6$  with 1.6 km/h

All values shown are for standard lift truck with standard equipment. If the truck is supplied with options, values may change. The specifications apply under normal operating conditions. All values given may vary + 5 % and - 10 % due the motor and system tolerances and represent nominal values obtained under typical operating conditions CLARK reserves the right to change products and specifications without prior notice.

# EQUIPMENT EXTRAS

## Upright table BST12

Upright type	Lift height (h3+h13)	Built height lowered (h1)	Height upright extended (h4)	Height upright extended (h4)	Freelift (h2)
			without load backrest	with load backrest	
	mm	mm	mm	mm	mm
Standard	2500	1840	3060	3500	-
	3000	2090	3560	4000	-
	3300	2200	3860	4300	-
	3500	2340	4060	4500	-

## Upright table BST12i

Upright type	Lift height (h3+h13)	Built height lowered (h1)	Height upright extended (h4)	Height upright extended (h4)	Freelift (h2)
			without load backrest	with load backrest	
	mm	mm	mm	mm	mm
Standard	2500	1872	3092	3532	-
	3000	2122	3592	4032	-
	3300	2272	3892	4332	-
	3500	2372	4092	4532	-

## Further Options

		BST12	BST12i
<b>General</b>	Low-maintenance drive motor	•	•
	Initial lift (BST12i only)		•
	Proportional lift as standard	•	•
	Electric driving, lifting and lowering	•	•
	Battery discharge indicator	•	•
<b>Battery and Charging Technology</b>	Battery 24 V / 60 Ah (Li-Ion) Charger 24 V / 25 A (integrated)	•	•
<b>Safety and Operation</b>	4-point support	•	•
	Activation via key switch	•	•
	Turtle mode function with raised tiller arm	•	•
	Safety screen (Perspex) on the mast	•	•
	TFT colour display in the tiller arm	X	X

• = Standard equipment; x = Option

# FEATURES & ADVANTAGES

## BST12

### Compact and clearly arranged

- Compact design with excellent visibility of forks and load
- Proportional lift as standard for precise lifting and lowering
- Laterally offset tiller arm for improved operator protection

### Operation

- Turtle mode function as standard
- Four-wheel concept for high stability
- Low centre of gravity for safe handling
- Electromagnetic parking brake
- BST12i: initial lift for double pallet transport and increased ground clearance

### Operator-friendly

- Quiet operation
- Ergonomically positioned controls
- Suitable for left- and right-handed users
- Adjustable support rollers

### Maintenance-friendly

- Dust- and splash-proof drive motor
- Battery discharge protection
- Low maintenance requirements
- TFT colour display in the tiller arm

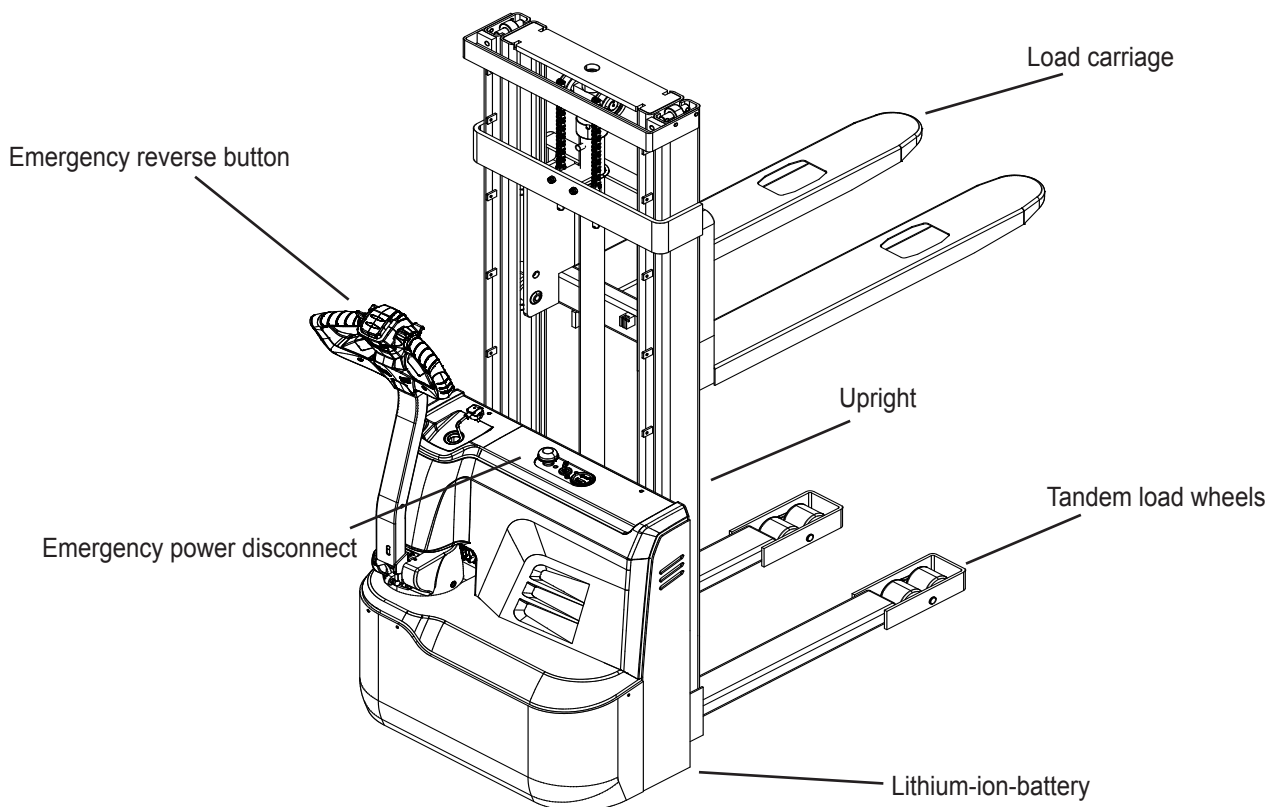

## BST12/BST12i

### BST12 – Electric Pallet Stacker

- For classic pallet transport and rack storage
- Simple, compact and economical

### BST12i – Electric Pallet Stacker with initial lift

- Double pallet transport up to 1,200 kg
- Increased ground clearance thanks to initial lift
- Safe driving over ramps and uneven floors

The BST12 and BST12i models are compact electric pallet stackers for daily use in warehouses, production and goods distribution. Both trucks are designed for precise work in confined areas and support stable handling, safe operation and easy control in pedestrian operation.

### Li-Ion Technology

Both models are equipped with a lithium-ion battery (24 V / 60 Ah) as standard. The battery is maintenance-free, durable and can be opportunity charged at any time without reducing service life.

The integrated charger (24 V / 25 A) enables charging from any standard 230 V socket, supporting high availability for changing shifts or additional requirements. Battery discharge protection helps protect the battery and supports long service life.

A key feature is the standard proportional lift, which enables smooth and precise lifting and lowering. This supports accurate load positioning and helps protect sensitive goods during storage and retrieval.

The BST12 is designed for classic pallet transport and standard storage and retrieval tasks. The BST12i also features an initial lift, enabling double pallet transport with a total load capacity of up to 1,200 kg. The initial lift also increases ground clearance, supporting safe driving over ramps, dock levellers and uneven floors.

Thanks to compact dimensions and a clear layout, both models provide excellent visibility of the forks and load.

### Easy Maintenance

The BST12 and BST12i are designed for low-maintenance operation. The encapsulated drive motor is dust- and splash-proof, supporting reliable operation in daily use.

Dealer:

CLARK Europe GmbH  
Dr.-Alfred-Herrhausen-Allee 33  
47228 Duisburg/Germany  
Tel.: +49 (0)2065 499 13-0  
Fax: +49 (0)2065 499 13-290  
E-Mail: [Info-europe@clarkmheu.com](mailto:Info-europe@clarkmheu.com)  
[www.clarkmheu.com](http://www.clarkmheu.com)