

BST12E

Lithium-Ion Stacker Truck ECO
1200 kg

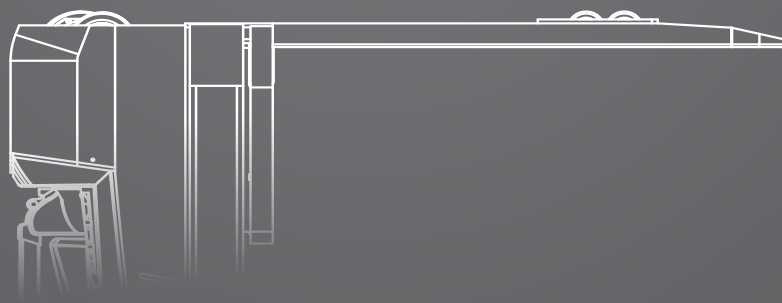
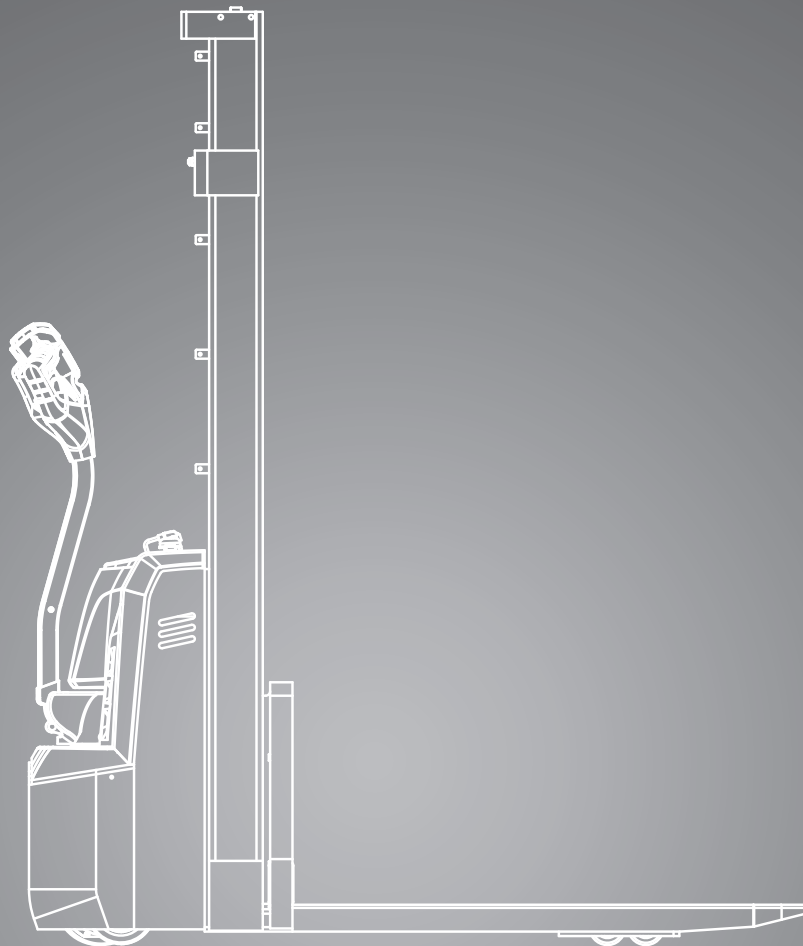

DIMENSIONS

BST12E

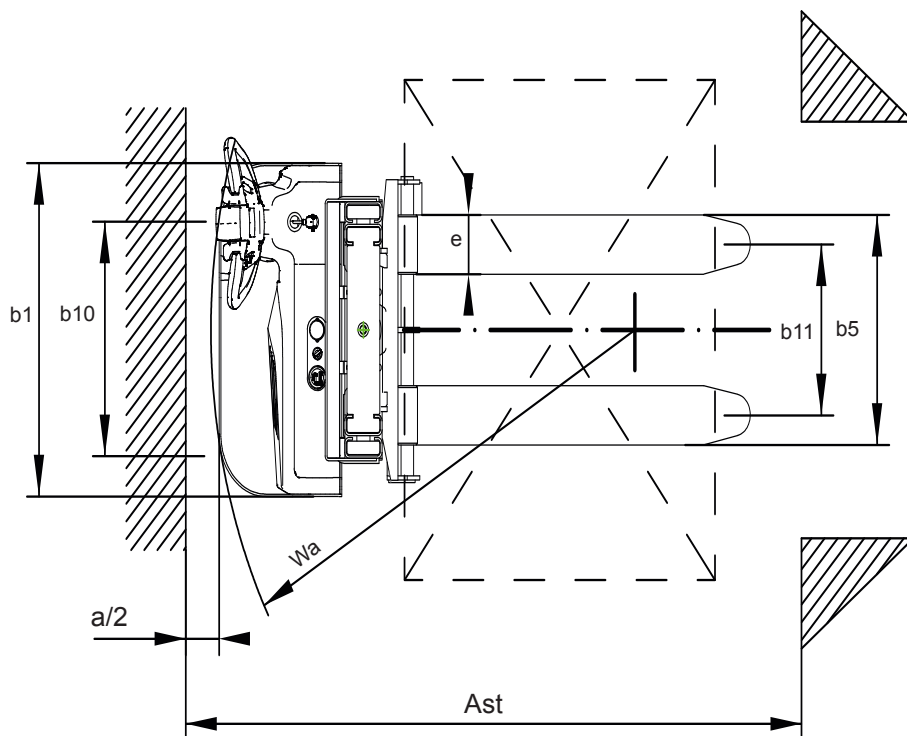
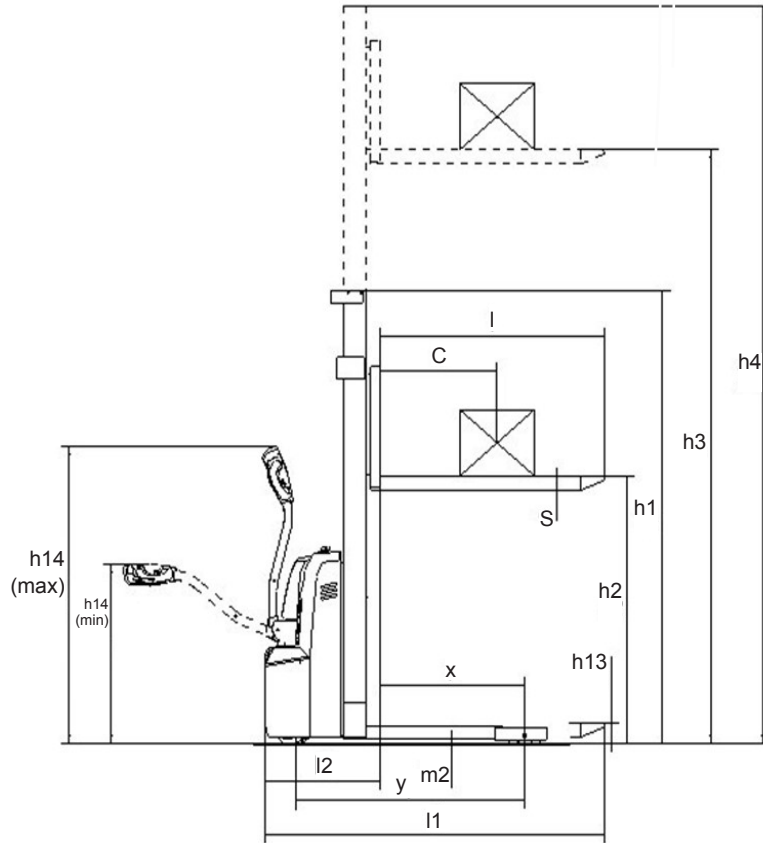

For corresponding data see specification chart.

SPECIFICATIONS

Product specification acc. to VDI 2198

	1.1	Manufacturer (Abbreviation)	CLARK
Specifications	1.2	Manufacturer's designation	BST12E
	1.3	Drive unit	Electric-24V
	1.4	Operator type stand on/driver seated	Pedestrian
	1.5	Load capacity/rated load	Q (kg) 1200
	1.6	Load centre distance	c (mm) 600
	1.8	Load distance, centre of drive axle to fork face	x (mm) 741
	1.9	Wheelbase	y (mm) 1180
Weight	2.1	Service weight	kg 525
	2.2	Axle loading, laden front/rear	kg 474 / 1251
	2.3	Axle loading, unladen front/rear	kg 386 / 139
Tyres, Chassis	3.1	Tyres	Polyurethane
	3.2	Tyre size, front	Ø 195 x 70
	3.3	Tyre size, rear	Ø 80 x 70
	3.4	Additional wheel (diemensions)	Ø 150 x 60
	3.5	Wheels, number front/rear (x = drive wheels)	1x+1/4
	3.6	Tread, front	b ₁₀ (mm) 523
	3.7	Tread, rear	b ₁₁ (mm) 410
Dimensions	4.2	Height of mast, lowered	h ₁ (mm) 2200
	4.4	Lift height *1	h ₃ (mm) 3300
	4.5	max.height of mast, extended	h ₄ (mm) 3860
	4.9	Height drawbar in driving position min./max.	h ₁₄ (mm) 670/1300
	4.15	Lowered fork height	h ₁₃ (mm) 90
	4.19	Overall length	l ₁ (mm) 1748
	4.20	Length to face of forks	l ₂ (mm) 598
	4.21	Width	b ₁ (mm) 800
	4.22	Fork dimensions	s*e*l (mm) 60*180*1150
	4.25	Width across forks min/max	b ₅ (mm) 570
	4.32	Ground clearance centre of wheelbase	m ₂ (mm) 30
	4.34.1	Stacking aisle for pallets (l6 · b12) 1000 x 1200 across	Ast (mm) 2218
	4.34.2	Stacking aisle for pallets (l6 · b12) 800 x 1200 along	Ast (mm) 2173
4.35	Turning radius	Wa (mm) 1365	
Performance	5.1	Travel speed laden/unladen	km/h 4.5 / 5.0
	5.2	Lift speed laden/unladen	m/s 0.12 / 0.18
	5.3	Lowering speed laden/unladen	m/s 0.16 / 0.14
	5.8	max. gradeability laden/unladen (S2 5 min.) *2	% 6 / 15
	5.10	Service brake	electro magnetic
Drive line	6.1	Drive motor output (S2 60 Min.)	kW 0.65
	6.2	Lift motor output S3 15 %	kW 2.2
	6.4	Battery voltage, nominal capacity K5	V/Ah 24/60
Misc.	6.5	Battery weight	kg 20
	10.7	Sound level, driver's ear DIN/EN 12053	dB (A) 70

*1) Further lifts heights to be found in mast overview *2) At friction coefficient $\mu=0.6$ with 1.6 km/h

All values shown are for standard lift truck with standard equipment. If the truck is supplied with options, values may change. The specifications apply under normal operating conditions. All values given may vary + 5 % and - 10 % due the motor and system tolerances and represent nominal values obtained under typical operating conditions. CLARK reserves the right to change products and specifications without prior notice.

EQUIPMENT EXTRAS

Upright table BST12E

Upright type	Lift height (h3+h13)	Built height lowered (h1)	Height upright extended (h4)	Height upright extended (h4)	Residual capacity
			without load backrest	with load backrest	
	mm	mm	mm	mm	mm
Standard	2500	1840	3060	3500	1000
	3000	2090	3560	4000	900
	3300	2200	3860	4300	800
	3500	2340	4060	4500	700

Further Options

		BST12E
General	Low-maintenance drive motor	•
	Proportional lift as standard	•
	Electric driving, lifting and lowering	•
	Battery discharge indicator	•
Battery and Charging Technology	Battery 24 V / 60 Ah (Li-Ion) Charger 24 V / 25 A (integrated)	•
Safety and Operation	4-point support	•
	Activation via key switch	•
	Turtle mode function with raised tiller arm	•
	Safety screen (Perspex) on the mast	•
	TFT colour display in the tiller arm	•

• = Standard equipment; x = Option

FEATURES & ADVANTAGES

BST12

Compact and clearly arranged

- Compact design with excellent visibility of forks and load
- Proportional lift as standard for precise lifting and lowering
- Laterally offset tiller arm for improved operator protection

Operation

- Turtle mode function as standard
- Four-wheel concept for high stability
- Low centre of gravity for safe handling
- Electromagnetic parking brake

Operator-friendly

- Quiet operation
- Ergonomically positioned controls
- Suitable for left- and right-handed users
- Adjustable support rollers

Maintenance-friendly

- Dust- and splash-proof drive motor
- Battery discharge protection
- Low maintenance requirements
- TFT colour display in the tiller arm

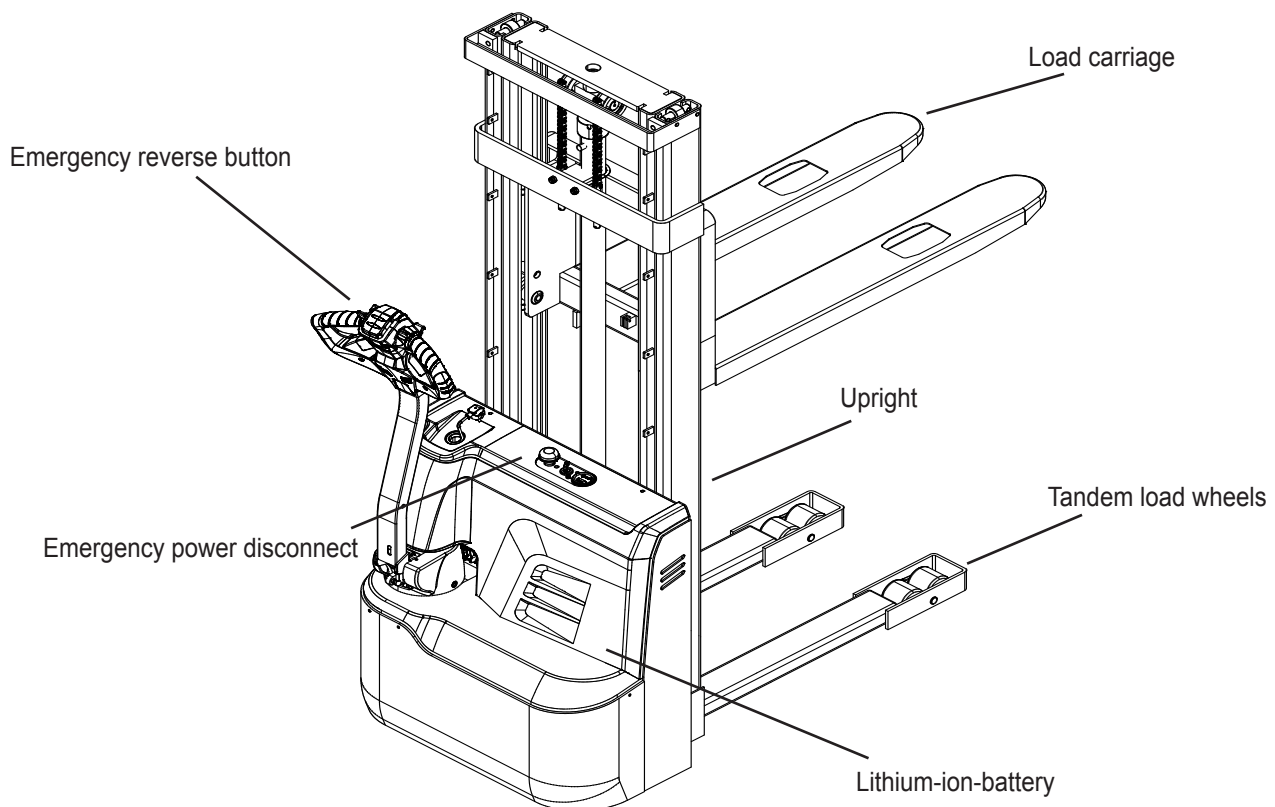

BST12E

BST12E – Electric Pallet Stacker

- For classic pallet transport and rack storage
- Simple, compact and economical

The BST12E model is a compact electric pallet stacker for an occasionally use in warehouses, production and goods distribution. The truck is designed for precise work in confined areas and supports stable handling, safe operation and easy control in pedestrian operation.

A key feature is the standard proportional lift, which enables smooth and precise lifting and lowering. This supports accurate load positioning and helps protect sensitive goods during storage and retrieval.

The BST12E is designed for classic pallet transport and standard storage and retrieval tasks. Thanks to its compact dimensions and clear design, this model provides an excellent view of the forks and load.

Easy Maintenance

The BST12E is designed for low-maintenance operation. The encapsulated drive motor is dust- and splash-proof, supporting reliable operation in daily use.

Li-Ion Technology

The model is equipped with a lithium-ion battery (24 V / 60 Ah) as standard. The battery is maintenance-free, durable and can be opportunity charged at any time without reducing service life.

The integrated charger (24 V / 25 A) enables charging from any standard 230 V socket, supporting high availability for changing shifts or additional requirements. Battery discharge protection helps protect the battery and supports long service life.

Dealer:

CLARK Europe GmbH
Dr.-Alfred-Herrhausen-Allee 33
47228 Duisburg / Germany
Tel.: +49 (0)2065 499 13-0
Fax: +49 (0)2065 499 13-290
E-Mail: Info-europe@clarkmheu.com
www.clarkmheu.com